

Introduction

The Enica Pulse-Splitter range is designed to split the pulse signal from a utility meter to several dataloggers. The device is passive and does not have any moving parts or batteries. The splitter can be used with electric, gas, water or in fact any meter with a pulse output (Volt-free contact, Reed relay or Open-collector).

For the purposes of gas meter installations, Enica Pulse Splitters provide no Intrinsic Safety isolation via optical or galvanic barriers and the Dangerous Substances and Explosive Atmospheres Regulations 2002 (DSEAR) and ATEX regulations must be adhered to.

Installation Procedure – Pulse-Splitter

Note: The standard version of the pulse splitter is not waterproof and is not suitable for use in wet environments such as water meter pits.

- Step 1:** Open the enclosure.
- Step 2:** Wire the pulse input (coming from the utility meter) to the terminals labelled INPUT. Please observe polarity if applicable.
- Step 3:** Wire the 1st datalogger to Output 1. Please observe polarity marked + and – on the terminal blocks
- Step 4:** Wire the 2nd and 3rd dataloggers to Output 2 and 3 respectively. Please observe polarity marked + and – on the terminal blocks
- Step 5:** Close the enclosure using the screws provided. Mount the Pulse-Splitter in a suitable location.

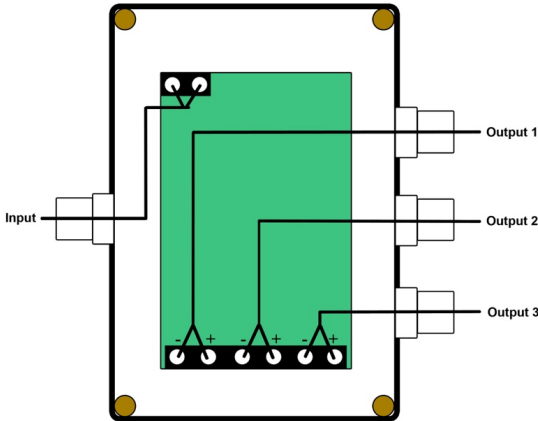

Installation Procedure – Waterproof Pulse Splitter

The waterproof version of the pulse splitter has all internal components encapsulated within waterproof gel compound. There are no serviceable parts inside and the enclosure should not be opened.

- Step 1:** Wire the pulse input (coming from the utility meter) to IN cable. Please observe polarity if applicable (White = Positive, Brown = Negative)
- Step 2:** Wire the 1st datalogger to any of the OUT cables. Please observe polarity on cable (White = Positive, Brown = Negative)
- Step 3:** Wire the 2nd and 3rd dataloggers the second and third OUT cables respectively. Please observe polarity on cable (White = Positive, Brown = Negative)

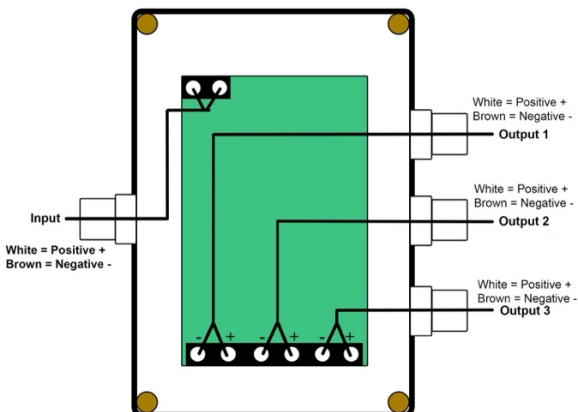

Safety Warnings

- No user serviceable parts inside.
- Observe the instructions and all warnings on the device and within these instructions.
- The installer/end-user is responsible for safe installation.
- Local working practices should be adhered to for installation.
- The enclosure of the device should be fully fitted.

Troubleshooting

In some circumstances, the splitter may show the following symptoms:

Pulses are received by a logger only when a single logger is connected to the splitter. When connecting a second or third logger, the pulses are not received by any device. In these cases, ensure pulse wiring makes a true circuit through the splitter and back to the meter and is not using an alternative common ground (-). This can be typical in some digital input modules with multiple inputs and is as a result of the logger electronics design rather than the splitter.

In some other cases, especially if the voltage being applied to the splitter from a logging device is low, the splitter can cause a slight volt drop in the logger output to the extent where the logger may not detect the pulses.

The splitter is designed to split digital (on/off) pulses. Ensure that the logging systems connected to the splitter have the same current type (AC or DC) coming from their Pulse/Digital Input. Do not connect loggers which use the opposite current type e.g. do not mix loggers that use AC with those that use DC.

Special Conditions

In some extreme conditions, the enclosure of the Pulse-Splitter may be capable of generating an electrostatic charge, which could potentially cause ignition. When the Pulse-Splitter is being used in a gas meter environment, the device shall not be positioned in such a way where external conditions are likely to cause an electrostatic charge on the enclosure of the device. In addition, the device shall only be cleaned with a damp or conductive cloth.

Disposal

The device must not be disposed of as unsorted waste and must be collected separately to ensure correct environmentally sound disposal. Where possible, the device should be returned to the manufacturer (or their authorised agent) for correct disposal. If this is not possible, your local Waste Disposal Authority should be consulted to ensure disposal in compliance with waste electrical and electronic equipment (WEEE) regulations that may be in force at the time.

Support and Contact Information

For technical support and queries, please contact:

Enica Ltd
Unit 7
Melin Corrwg Business Parc
Upper Boat
PONTYPRIDD
CF37 5BE

Tel: +44 (0)1443 844224
Fax: +44 (0)1443 381000
Email: sales@enica.co.uk

Legal Notice

The information contained in this document is subject to change without notice. Enica Ltd makes not warranty of any kind with regards to this document include, but not limited to, the implied warranties of sale and fitness for purpose. Enica Ltd shall not be liable for errors contained herein or for incidental or consequential damages in connection with the use of this document.

